

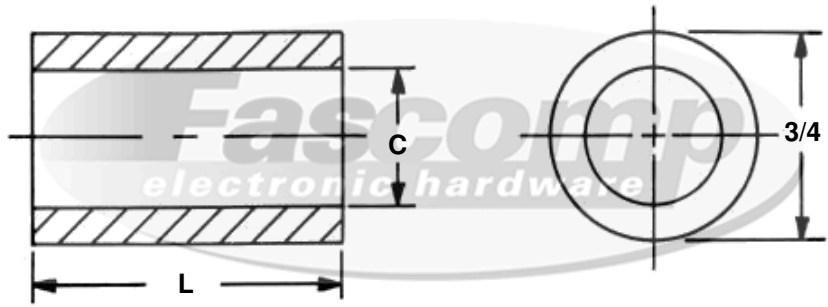

3/4 Round Spacers



Hex Code Table		
✓	FMXXXX	Length (L)
	FC1277	1/8
	FC1278	3/16
	FC1279	1/4
	FC1280	5/16
	FC1281	3/8
	FC1282	7/16
	FC1283	1/2
	FC1284	9/16
	FC1285	5/8
	FC1286	11/16
	FC1287	3/4
	FC1288	13/16
	FC1289	7/8
	FC1290	15/16
	FC1291	1
	FC1292	1-1/16
	FC1293	1-1/8
	FC1294	1-3/16
	FC1295	1-1/4
	FC1296	1-5/16
	FC1297	1-3/8
	FC1298	1-7/16
	FC1299	1-1/2
	FC1300	1-9/16
	FC1301	1-5/8
	FC1302	1-11/16
	FC1303	1-3/4
	FC1304	1-13/16
	FC1305	1-7/8
	FC1306	1-15/16
	FC1307	2

Create a part number:

Length	Clearance	Material	Finish
FCXXXX	XX	XX	XX
<div style="border-top: 1px solid black; border-bottom: 1px solid black; width: 100%;"></div>			

Hole Clearance Code (XX)		
✓	Code (XX)	C + .010
	6	.140
	8	.166
	10	.192
	12	.218
	25	.252
	31	.315
	38	.380
	43	.440
	50	.505

Material		
✓ Material Code (XX)		
A	Aluminum	
B	Brass	
S	Steel	
SS	Stainless Steel	
N	Nylon	

Tolerances Unless otherwise Specified
 .xxx +/- .005
 .xx +/- .010
 Angular +/- 1 Degree
 Linear +/- .005
Break all sharp edges

✓ Compatible Finish (XX)		
A, B, S, SS	0 - Plain	
B, S	5 - Nickel Plate (QQ-N-290)	
A	6 - Iridite #14 Gold (MIL-C-5541E)	
A	7 - Iridite Clear (MIL-C-5541E)	
A	9 - Alodine 1200	
B, S	12 - Zinc Clear (ASTM-B-633)	
B, S	16 - Electro Tin (MIL-T-10727 TYPE 1)	
SS	20 - Passivation (MIL-F-14072D)	
A	22 - Clear Anodize (MIL-A-8625-TYPE2) (Sulphuric) Hot Water Seal (Clear)	
A	24 - Black Anodize (MIL-A-8625)	
B, S, SS	26 - Black Oxide	
B, S	28 - Zinc Yellow (ASTM-B-633)	

This document is the property of Fascomp Inc. and shall not be reproduced, distributed, or used as a basis for manufacturing without written permission from Fascomp Inc.

Source Control Drawing:
 To be produced by
 Fascomp Electronic
 Hardware

